

RIGID COUPLINGS

ROLL GROOVE

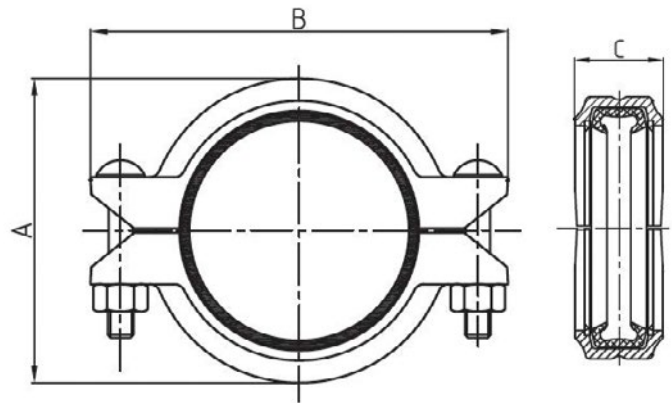

GVF CODE		DN SIZE (mm)	SUITS OD (mm)	A (mm)	B (mm)	C (mm)	WEIGHT (kg)
PAINTED	GALV						
RGC025	RGC025G	25	33.4	59	100	44	0.52
RGC032	RGC032G	32	42.2	66	105	45	0.61
RGC040	RGC040G	40	48.3	72	112	45	0.64
RGC050	RGC050G	50	60.3	85	130	45	0.72
RGC065	RGC065G	65	76.1	100	140	45	0.85
RGC080	RGC080G	80	88.9	114	160	45	1.25
RGC100	RGC100G	100	114.3	140	187	50	1.88
RGC125	RGC125G	125	141.3	170	225	50	2.41
RGC150	RGC150G	150	165.1	195	250	50	2.71
RGC150X	RGC150XG	150	168.3	200	255	50	2.89
RGC200	RGC200G	200	219.1	255	322	58	5.73
RGC250	RGC250G	250	273	318	410	63	7.79
RGC300	RGC300G	300	323.9	370	465	63	9.77

MATERIALS	
Body	Ductile Iron
Gasket	EPDM

SPECIFICATIONS
Cold Working Pressure
1600 kPa / 300 PSI

STANDARD
Material
ASTM A536
Design
AWWA C606



VALVES
GALVANISED MALLEABLE
STAINLESS STEEL FITTINGS
BLACK & GAL STEEL FITTINGS
HIGH PRESSURE FITTINGS
CAMLOCKS
ROLL GROOVE
BUTTWELD
FLANGES